

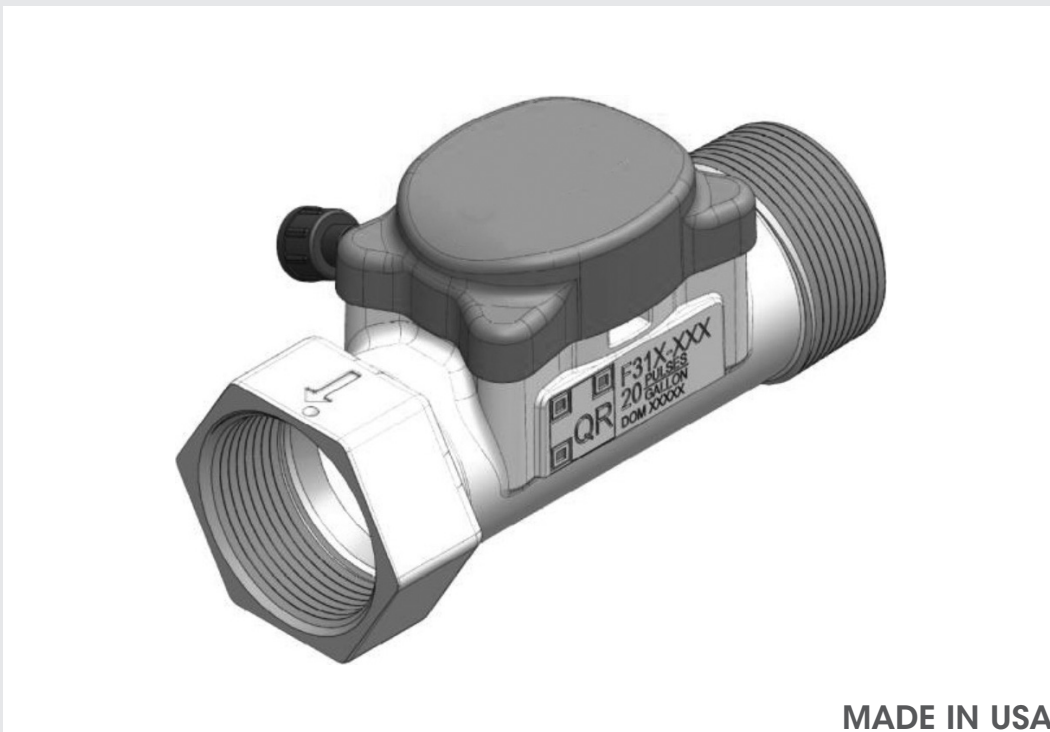

## ULTRASONIC INLINE FLOW METERS

FOR ACCURATE FLOW MEASUREMENT



MADE IN USA

- 1 INCH ULTRASONIC FLOW METER NPT THREAD TYPE MODEL: QA-FM100
- 1 INCH ULTRASONIC FLOW METER BSP THREAD TYPE MODEL: QA-FM100BSP
- 1.5 INCH ULTRASONIC FLOW METER NPT THREAD TYPE MODEL: QA-FM150
- 1.5 INCH ULTRASONIC FLOW METER BSP THREAD TYPE MODEL: QA-FM150BS
- 2 INCH ULTRASONIC FLOW METER NPT THREAD TYPE MODEL: QA-FM200
- 2 INCH ULTRASONIC FLOW METER BSP THREAD TYPE MODEL: QA-FM200BSP
- 3 INCH ULTRASONIC FLOW METER NPT THREAD TYPE MODEL: QA-FM300
- 3 INCH ULTRASONIC FLOW METER BSP THREAD TYPE MODEL: QA-FM300BSP

## Table of Contents

3. Specifications
4. Dimensions and Identification
5. Application Guide
6. Application Guide (continued)
7. Parts and Accessories
8. Troubleshooting

## Specifications

The Ultrasonic Inline Flow Meters are engineered to elevate water treatment and usage measurement. Composed of stainless steel construction and no internal moving parts, these flow meters ensure durability and reliability even in the most demanding environments.

The ultrasonic meter module operates as a pulse generating device with corresponding "K Factor" for accurate flow measurement when connected to commonly used industry controls.



## Flow Performance

Part Number	Pipe Size Inches	Thread Type	Operating Range			K Factor Pulses/Gal
			Low Flow Threshold	Typical Flow 0.1 ft/sec to 10 ft/sec	Max Flow 16 ft/sec	
QA-FM100	1.0	NPT	0.12 gpm (0.45 lpm)	0.3 to 24.5 gpm (1.1 to 93 lpm)	39 gpm (147 lpm)	40 (10.57/Liter)
QA-FM100BSP	1.0	BSP	0.12 gpm (0.45 lpm)	0.3 to 24.5 gpm (1.1 to 93 lpm)	39 gpm (147 lpm)	40 (10.57/Liter)
QA-FM150	1.5	NPT	0.25 gpm (0.95 lpm)	0.6 to 55.1 gpm (2.3 to 209 lpm)	88 gpm (333 lpm)	30 (7.93/Liter)
QA-FM150BSP	1.5	BSP	0.25 gpm (0.95 lpm)	0.6 to 55.1 gpm (2.3 to 209 lpm)	88 gpm (333 lpm)	30 (7.93/Liter)
QA-FM200	2.0	NPT	0.45 gpm (1.7 lpm)	1.0 to 98.0 gpm (3.8 to 371 lpm)	156 gpm (590 lpm)	20 (5.28/Liter)
QA-FM200BSP	2.0	BSP	0.45 gpm (1.7 lpm)	1.0 to 98.0 gpm (3.8 to 371 lpm)	156 gpm (590 lpm)	20 (5.28/Liter)
QA-FM300	3.0	NPT	1.4 gpm (5.3 lpm)	2.2 to 220.5 gpm (10.6 to 835 lpm)	353 gpm (1336 lpm)	10 (2.64/Liter)
QA-FM300BSP	3.0	BSP	1.4 gpm (5.3 lpm)	2.2 to 220.5 gpm (10.6 to 835 lpm)	353 gpm (1336 lpm)	10 (2.64/Liter)

**NOTE: UPC recommends that water velocity within plumbed systems should not exceed 8 ft/sec.**

QA-FM100

QA-FM150

QA-FM200

QA-FM300



## Operating Specifications

Max Pressure	125 psi (8.6 bar)
Temperature Range	34°F (1°C) to 100°F (38°C)
Operating Power	5 to 24VDC, .03 Amp min

## Dimensions and Identification

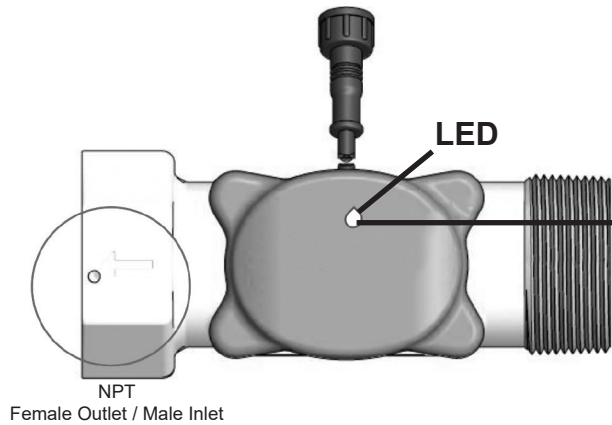

On Power Up:		
1 Flash	QA-FM100	1 inch
2 Flashes	QA-FM150	1.5 inches
3 Flashes	QA-FM200	2 inches
4 Flashes	QA-FM300	3 inches

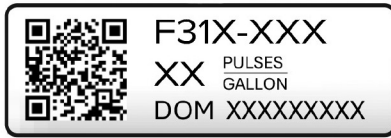
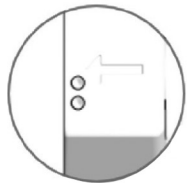

### DURING OPERATION

LED flashes as forward flow is sensed within the meter.

Flashing is proportional to the rate of flow sensed.

IE: Higher flow rate produces higher frequency of flashing.

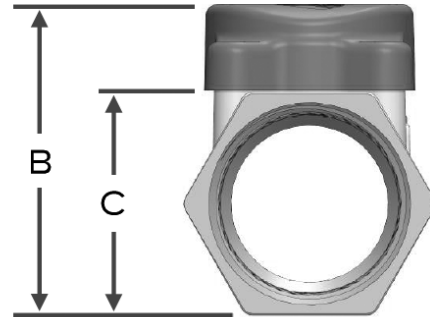
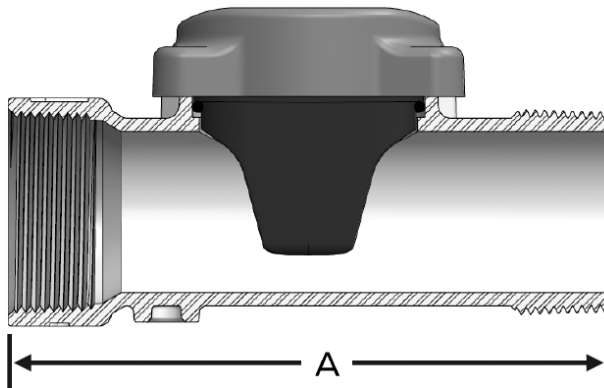

Part Number	Pipe Size Inches	Thread Type	Dimensions			Weight Lbs
			Overall Length (Dim A) Inches	Overall Height (Dim B) Inches	Hex Width Flat to Flat (Dim C) Inches	
QA-FM100	1.0	NPT/BSP	5.6	2.5	1.6	1.7
QA-FM150	1.5	NPT/BSP	5.6	3.0	2.1	2.0
QA-FM200	2.0	NPT/BSP	5.6	3.5	2.6	2.4
QA-FM300	3.0	NPT/BSP	6.9	4.5	3.8	4.2

## Application Guide

Inline flow meters are most accurate when measuring fully developed, non-turbulent flow. The ultrasonic meters have been calibrated for measuring liquids and may not read accurately if air or other gasses are in the pipe. Orient the meter to minimize entrapped gasses around the sensors.

These recommendations are meant to guide the installation and meter orientation to promote a full pipe condition. They are also meant to provide accessibility to the meter cap for viewing flow indicator and servicing.

The meter can be installed in horizontal or vertical orientations. The meter sensor module can be aligned at any angle in the plumbing.

The operation of the ultrasonic meter requires that the "flow hoop" remain full without air bubbles at all times. Mounting the meter vertically with flow in the downward direction may not be advisable in some installations.

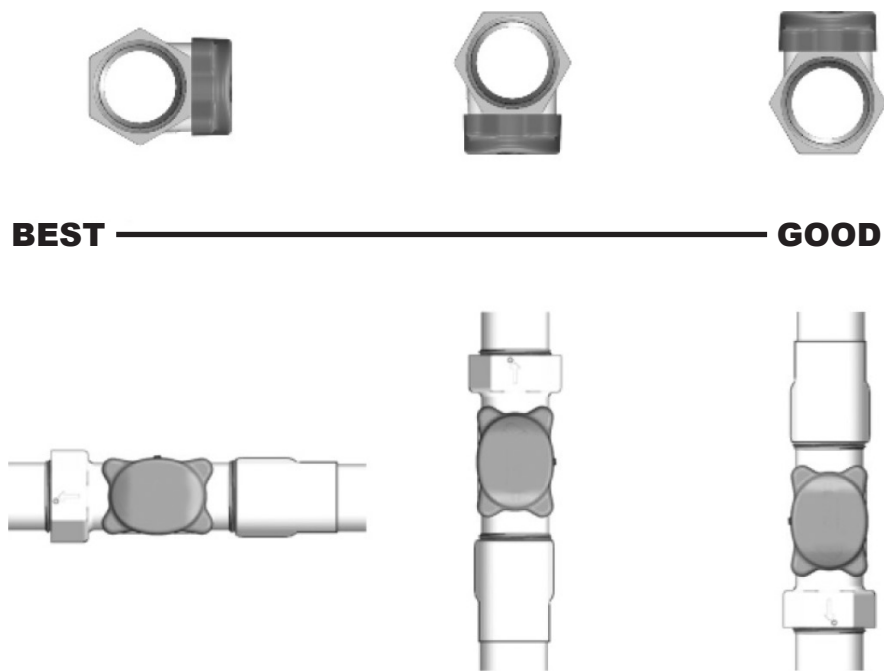

Do not run flow meter wiring in direct proximity to power line wiring. If connecting to one of the water treatment controls listed below, insert wires into the three-pin connector as shown. If connecting to another type of control, cut off the three-pin connector and strip wires as needed.

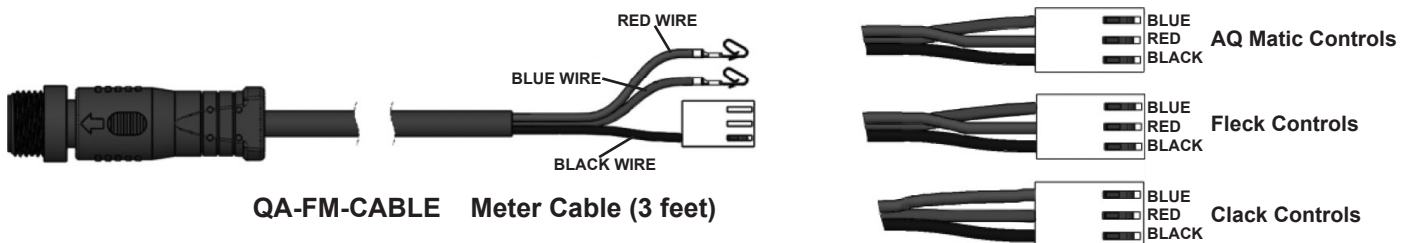

## Application Guide (continued)

Observe the flow direction arrow on the meter body. For maximum accuracy, allow 10 pipe diameters of straight pipe before the meter and 5 pipe diameters after the meter. The straight pipe recommendation is to reduce turbulence in high flow velocity conditions. For example, if installing a 1.5 inch meter, there should be 15 inches (1.5 inch x 10 = 15 inch) of straight pipe before and 7.5 inches (1.5 inch x 5 = 7.5 inch) of straight pipe after the meter for the best accuracy.

Meter accuracy has been tested with units attached to the outlet of control valves.

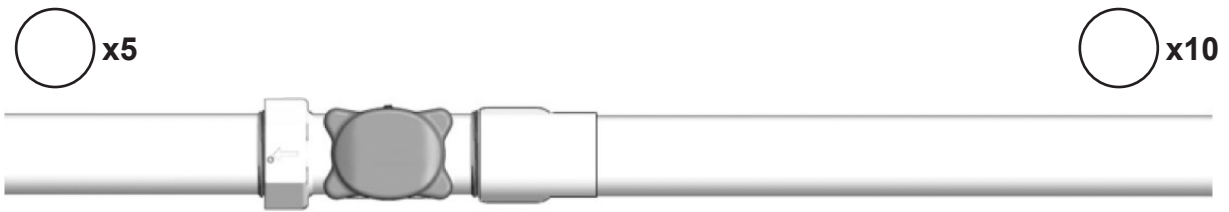

A set of dip switches are provided on the circuit board to set the meter size. On flow meter assemblies these dip switches are preset at the factory and do not require adjustment.

When replacing a flow sensor module verify the dip switch setting as shown below:

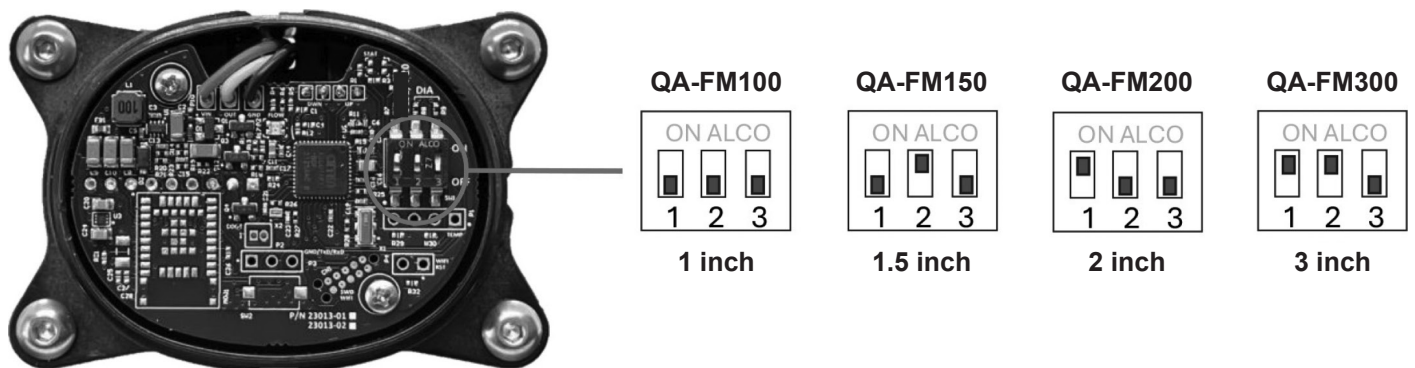

# Parts and Accessories

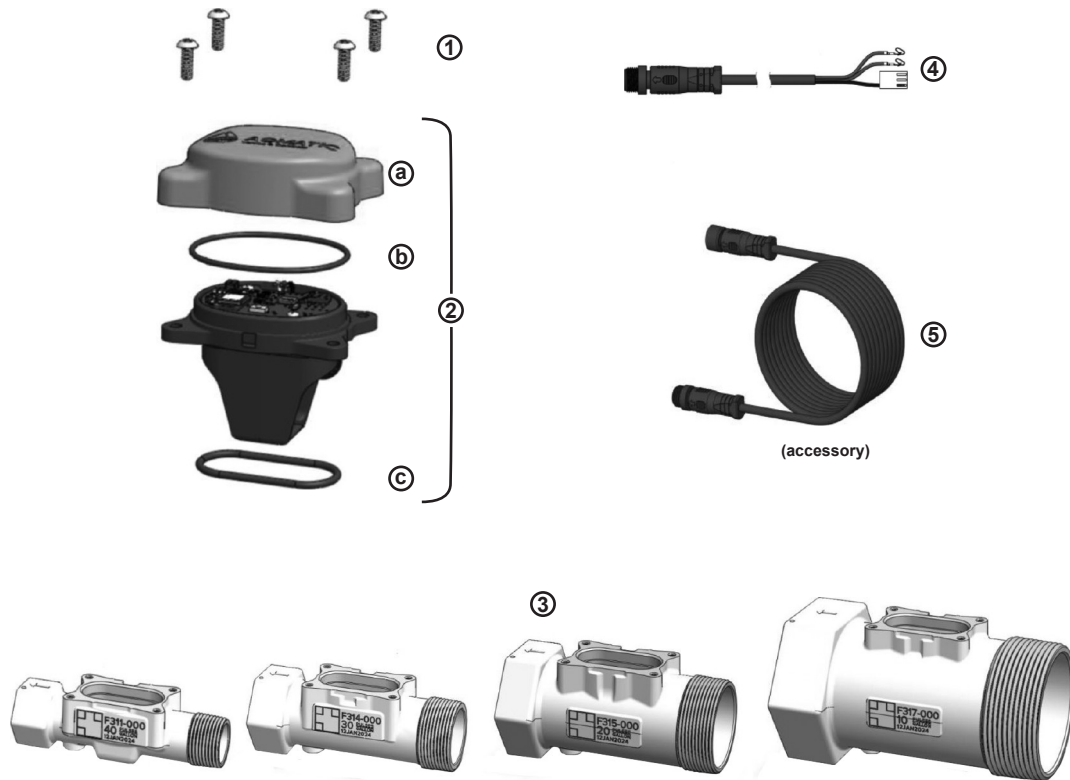

Location	Description	Part Number	Quantity
1	Screw, #8 - 32 x 0.5	QA-FM-SCREW	4
2	Meter Sensor Module	QA-FM-SENSOR ASSY	1
a	Cover, Flow Meter	QA-FM-SENSOR COVER	1
b	O-ring, Meter Cover	QA-FM- SENSOR O-RING	1
c	O-ring, Meter Cover	QA-FM- METER O-RING	1
3	Meter Body, FM100, NPT	QA-FM100-BODY NPT	1
	Meter Body, FM100, BSP	QA-FM100-BODY BSP	
	Meter Body, FM150, NPT	QA-FM150-BODY NPT	
	Meter Body, FM150, BSP	QA-FM150-BODY BSP	
	Meter Body, FM200, NPT	QA-FM200-BODY NPT	
	Meter Body, FM200, BSP	QA-FM200-BODY BSP	
	Meter Body, FM300, NPT	QA-FM300-BODY NPT	
	Meter Body, FM300, BSP	QA-FM300-BODY BSP	
4	Meter Cable (3 feet)	QA-FM-CABLE	1
5	Meter Cable Extension (8 feet)	QA-FM-CABLEEXT	(optional)

## Troubleshooting

Flow Meter Malfunctioning	Insufficient power	When plugging in the wire harness, the LED should flash. This sequence of flashes will indicate the size meter the module is set for. If it does not, check for 5-24VDC on red (power) wire.
	Cable connection not properly made	Verify that meter cable ends are properly connected at control and at threaded plug end on meter module.
	Gas or air in pipe	When flow is being registered by the sensor, the LED should flash proportional to flow rate. Orient meter to minimize entrapped gas on flow sensors.
	Improperly set dip switch	Check manual for dip switch setting matching the meter model and adjust as needed.
	Damaged or bad circuit board	Replace flow sensor module.